

Cuisinart®

INSTRUCTION AND
RECIPE BOOKLET



Pastafecto® Pasta/Bread Dough Maker

PM-1C Series

For your safety and continued enjoyment of this product, always read the instruction book carefully before using.

IMPORTANT SAFEGUARDS

When using an electrical appliance, basic safety precautions should always be taken, including the following:

- 1. READ ALL INSTRUCTIONS, PRODUCT LABELS AND WARNINGS BEFORE USING THIS PASTA/BREAD DOUGH MAKER.**
2. Do not touch hot surfaces; carry the unit by plastic base. Always use oven mitts when handling hot material, and allow metal parts to cool before cleaning. Allow the pasta/bread dough maker to cool thoroughly before putting on or taking off parts.
3. Turn the appliance STOP, then unplug from the outlet when not in use, before assembling or disassembling parts and before cleaning. To unplug, grasp the plug and pull from the outlet. Never pull from the power cord.
4. To protect against risk of electric shock, do not immerse the appliance or plugs or cord in water or other liquids.
5. This appliance is not intended for use by children or by persons with reduced physical, sensory, or mental capabilities, or lack of experience and knowledge. Close supervision is necessary when any appliance is used near children. Children should be supervised to ensure that they do not play with the appliance.
6. Do not allow anything to rest on the power cord. Do not plug in cord where people may walk or trip on it. Unplug this pasta/bread dough maker from the wall outlet when not in use, before you leave for a trip, or go out for a long period of time.
7. Do not operate any appliance with a damaged cord or plug or after the appliance malfunctions, or is dropped or damaged in any manner. Contact the manufacturer at their customer service telephone number for information on examination, repair, or adjustment.
8. Do not let the cord dangle over the edge of a table or counter, or touch hot surfaces. Do not place on an unsteady or cloth-covered surface.
9. Avoid contact with moving parts.
10. Do not use attachments not recommended by the manufacturer. They may cause fire, electric shock or injury, or may damage the unit and void the warranty.
11. Do not use outdoors or for commercial purposes.
12. Do not place the appliance near a hot gas or electric burner, or in a heated oven.
13. Keep power cord away from the hot surface of this pasta/bread dough maker. Do not put any flammable objects on the hot surface of this pasta/bread dough maker.
14. Place this pasta/bread dough maker a minimum of 2 inches (5 cm) away from any wall or other object.
15. Do not use this pasta/bread dough maker for other than its intended use.
16. When plugging or unplugging this pasta/bread dough maker, be sure not to touch the plug blades with your fingers.
17. Before unplugging, press and hold the START/STOP button for 1 to 3 seconds to cancel any programs, then grip plug and pull from wall outlet. Never pull on the cord.
18. Use of extension cords: A short power-supply cord has been provided to reduce the risk of injury resulting from

-
- becoming entangled in or tripping over a longer cord. Extension cords may be used with care. The marked electrical rating of the extension cord should be at least as great as the electrical rating of the appliance. The cord should be arranged so that it will not drape over the counter or tabletop where it can be pulled by children or tripped over accidentally. If the appliance is of the grounded type, the extension cord should be a grounding-type 3-wire cord.
19. If electric circuit is overloaded with other appliances, your pasta/bread dough maker may not operate properly. This pasta/bread dough maker should be operated on a separate electrical circuit from other operating appliances.
 20. Do not operate your appliance in an appliance garage or under a wall cabinet. **When storing in an appliance garage, always unplug the unit from the electrical outlet.** Not doing so could create a risk of fire, especially if the appliance touches the walls of the garage or the door touches the unit as it closes.
 21. Preheating of the appliance is necessary.
 22. For household use only.
 23. This appliance is not intended for use by persons (including children) with reduced physical, sensory or mental capabilities, or lack of experience and knowledge, unless they have been given supervision or instruction concerning use of the appliance by a person responsible for their safety.
 24. Children should be supervised to ensure that they do not play with the appliance.

25. Appliances are not intended to be operated by means of an external timer or separate remote-control system.
26. Do not exceed the maximum operation cycle of 2 cycles continuously at all applications. Make sure the shaping disc hole is unblocked each time before using.
27. Do not attempt to defeat the cover interlock mechanism.

SAVE THESE INSTRUCTIONS FOR HOUSEHOLD USE ONLY

CONTENTS

Important Safeguards.....	2
Parts and Features	4
Before First Use	5
Disassembling Your Pasta/Bread Dough Maker	6
Putting Together Your Pasta/Bread Dough Maker	7
Cleaning and Care	9
Troubleshooting	9
Recipes	10
Warranty.....	29

PARTS AND FEATURES

1. Mixing Bowl Lid
2. Mixing Bowl
3. Cutting Tool
4. Disc Holder
5. Locknut
6. Storage Drawer
7. Pasta Discs (6)
 - a. Bucatini
 - b. Spaghetti
 - c. Fusilli
 - d. Rigatoni
 - e. Small Macaroni
 - f. Fettucine
8. Pasta Mixing Paddle
9. Dough Kneading Paddle
10. Auger
11. Auger Sleeve
12. Dry 1 Cup (237 ml) Measure
13. Liquid 1 Cup (250 ml) Measure
14. Storage Bag
15. Cleaning Brush with Rotating Pin Head

Bristle brush clears away excess flour; pin swivels open to poke out pasta from the shaping discs.

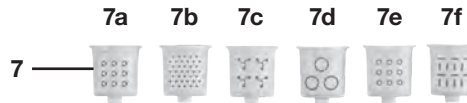

BEFORE FIRST USE

Remove all packing material and any promotional labels or stickers from your pasta/bread dough maker. Be sure that all parts of your new pasta/bread dough maker have been unpacked before discarding any packing materials. You may want to keep the box and packing materials for use at a later date.

Wipe housing with a damp cloth to remove any dust from the warehouse or shipping.

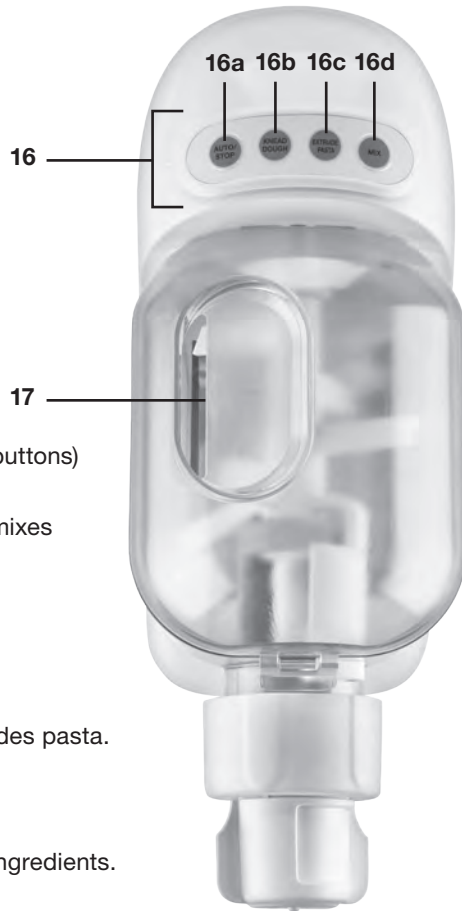

16. Control Panel (4 buttons)

a. Auto Stop

Automatically mixes and extrudes pasta dough.

b. Knead Dough

Kneads yeast bread doughs.

c. Extrude Pasta

Manually extrudes pasta.

d. Mix

Manually mix.

17. Opening in Lid

For adding liquid ingredients.

DISASSEMBLING YOUR PASTA/BREAD DOUGH MAKER

NOTE: For details on numbered parts, reference Parts and Features section on page 4.

1. Lift the tab on the front of the mixing bowl lid (1) to remove.



2. Pull to remove cutting tool (3).



3. Turn locknut (5) counterclockwise to unscrew and remove the locknut.



4. Pull to remove the disc holder (4).



5. Remove auger (10) and auger sleeve (11).

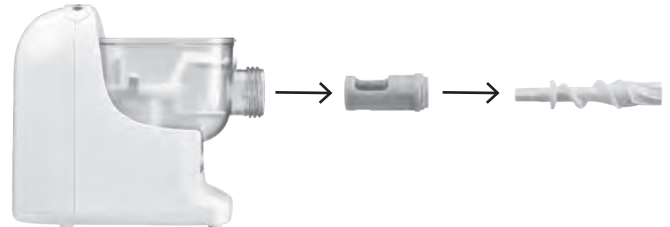

6. Remove the mixing bowl by sliding forward, then remove the pasta mixing paddle (8).



7. Clean all parts in mild, soapy water before use.

PUTTING TOGETHER YOUR PASTA/BREAD DOUGH MAKER

1. Slide the mixing bowl (2) onto the base of the pasta/bread dough maker.



2. Place the pasta (8) or bread paddles (9) into the mixing bowl and secure the bowl.



3. Insert the auger sleeve (11) through the opening in the mixing bowl. Insert with opening facing up.



4. Insert the auger (10) into the auger sleeve (11).



5. Select the pasta disc (7a-f) you will use.



6. Assemble the pasta disc holder (4) with the selected pasta disc (7a-f), and position onto the auger. Pasta disc should be facing down.

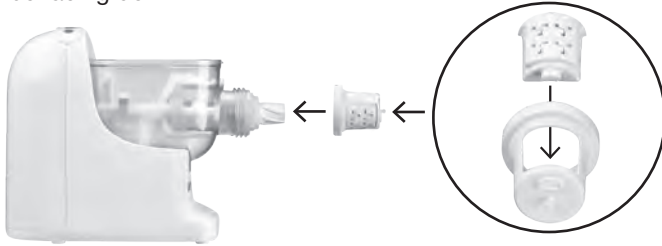

7. Use the locknut (5) to secure and lock the pasta disc holder (4) into place.



8. For extruding pasta, push the cutting tool (3) onto the disc holder (4) until secure. Position so the window of the cutting tool is framing the pasta disc.



9. Your pasta/bread dough maker is now ready to make up to 1 pound (454 g) of fresh pasta or 1 pound (454 g) of bread dough.

10. Place all the dry ingredients into the mixing bowl. Place the lid on the bowl and lock into place.



11. Plug in the unit and select the correct function according to your recipe. Do not pour water into the mixing chamber before the pasta/bread dough maker starts running.



12. Once the unit is running, pour your liquid ingredients through the ingredient hole in the top of the unit.

NOTE:

- For making pasta, do not put less than 2 cups/250 g, or more than 3 cups/375 g of flour in the chamber; for making bread dough, do not put less than 2 cups/250 g, or more than

3¼ cups/400 g of flour in the mixing bowl. If you put too little or too much flour in the mixing bowl, the appliance will not operate as intended.

- Do not pour the flour into the opening of the auger sleeve (A), as the flour in the auger sleeve will not be mixed evenly.

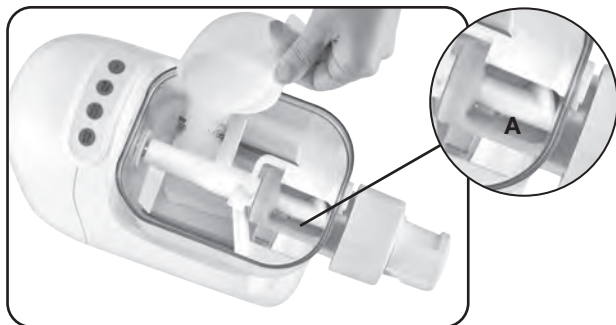

CLEANING AND CARE

CAUTION: Unplug machine before cleaning. Do not put the pasta/bread dough maker in water or in dishwasher. Do not use scrubbing brushes or chemical cleaners, as these will damage the machine.

Lid and Bowl

May be washed in warm, soapy water. Wipe.

Control Panel

Wipe with a slightly damp cloth as necessary. Take care not to allow water or cleaning fluids under buttons of control panel.

Housing

Using a damp sponge or cloth, clean the flour residue.

Pasta Discs

Pasta discs should be left to dry with the dough on them, and then brushed clean using the cleaning tool. Letting the pasta dough dry will make it easier to clean with the tool.

Dishwasher-Safe Parts

All detachable parts are dishwasher safe.

MAINTENANCE

Any other servicing should be performed by an authorized service representative.

TROUBLESHOOTING

During the pasta making process, the appliance stops working.

Possible Causes:

- The pasta maker has overheated due to long and continuous working time. Disconnect from the power source, and allow the pasta maker to cool down. To better protect the lifetime of the appliance, the continuous working time should be less than 40 minutes. You can use the appliance again after 30 minutes of rest.
- The ratio of flour and water is incorrect — the dough may be too dry.
- There's too much flour in the mixing bowl.

The mixing paddle is running idle, and there is no pasta coming out.

Possible Cause:

- The ratio of the flour and water is incorrect. Disconnect the plug from the power source and discard dough. Clean the pasta maker, measure ingredients correctly (use a kitchen

scale to measure the flour weight more accurately), and follow the user manual again to restart the pasta making.

The pasta breaks easily.

Possible Cause:

- The ratio of the flour and water is incorrect.

The pasta sticks together.

Possible Cause:

- The ratio of the flour and water is incorrect or too much water has been poured in the mixing bowl.

Too much leftover dough inside the bowl.

Possible Causes:

- The flour has been either exposed to moisture before use, or the dough is too wet. Keep your flour dry during storage. Follow the user manual instructions to restart the pasta making.
- The chamber, the mixing paddle and/or the shaping disc have not been cleaned properly before use. Make sure all parts are clean before use.
- The mixing paddle or the chamber is still wet. Make sure all parts are completely dry before use.
- Water has not been added in the right order.
- The flour type is not suitable.

The bowl lid is pushed open from the inside.

Possible Cause:

- There's too much flour in the mixing bowl.

Note: To avoid many problems, be sure to follow the instructions in this manual for making pasta.

RECIPES

Tips and Hints.....	11
Pasta Recipe Chart.....	13
Vegetable Purées for Colored Pasta	
Beet Purée for Red-Colored Pasta	14
Butternut Squash Purée for Orange-Colored Pasta.....	14
Spinach Purée for Green-Colored Pasta	14
Sauces and Dishes	
Tomato Sauce	15
Smoky Vodka Sauce.....	16
Alfredo Sauce	16
Garden Vegetable Sauce.....	17
Garlic and Oil Sauce.....	18
Sautéed Mushroom and Butter Sauce	18
Basil Pesto	19
Sunday Ragu.....	19
Classic Meatballs.....	20
Pad Thai	21
Bread	
Classic Cuisinart® White Bread.....	22
Classic Cuisinart® Wheat Bread.....	23
Challah	24
Buttery Dinner Rolls.....	25
Rosemary Olive Oil Rolls	26
Pizza Dough.....	27

TIPS AND HINTS

Tips for Making Pasta Noodles

- When followed precisely, the ratios in the Pasta Chart should extrude perfect pasta every time. Still, external factors can affect your results, such as humidity, flour freshness and measuring style. Keep in mind that there is considerable variation in weight per cup (250 ml) of flour between different brands.
- Weight measurements will always yield the most consistent results. If you don't own a digital food scale, take care in how you measure your flour. For the most accurate measurement, first stir the flour, then gently spoon into the measuring cup and level off the top.
- **During the mixing cycle, do not be alarmed if the pasta dough appears dry. The proper consistency should resemble a coarse meal.**
- When adding liquids, add the egg first through the opening in the lid. Then add the water slowly, holding a small amount back to ensure the correct consistency is achieved. Purées are too thick to pass through the opening and should be added directly into the mixing bowl along with dry ingredients.
- Pasta dough will not extrude if it becomes too wet. Hold back 1 to 2 tablespoons (15 to 30 ml) of the water in the pasta recipe, as the dough may not require the full measurement. If pasta will not extrude, the unit will phase back to mixing – this can be an indication that the mixture is too dry. In this case, add the remaining 1 to 2 tablespoons (15 to 30 ml) of water, a little at a time, to achieve the proper consistency. It is possible that you may require even more water than the recipe calls for.

- As extrusion occurs, cut pasta noodles to desired length and place on a parchment-lined sheet pan. Loosely fold long pasta noodles into nests and dust lightly with flour to keep strands from sticking together.

Tips for Cooking and Storing Pasta Noodles

- After extruding, cook pasta immediately or store it in the refrigerator for up to 2 days. Uncooked pasta may be frozen for up to 3 weeks – place the sheet pan of cut pasta noodles in the freezer until semi-frozen, then transfer to freezer bags.
- Cook pasta in a large pot of boiling, salted water to desired doneness. The cooking time for pasta will differ slightly between recipes and the disc shape used. Refer to the Pasta Chart for recommended cooking times.

Tips for Rice Noodles

- When choosing a rice flour to make rice noodles, look for varieties labeled “superfine.”
- Rice flour is naturally gluten-free and therefore requires binding agents, such as tapioca flour and xanthan gum for making noodles.
- During mixing, water should be added sparingly, as the rice noodle dough can quickly turn into a paste if too much water is added – this will prevent the dough from entering the auger for extrusion.
- Transferring cooked rice noodles immediately to an ice bath will halt cooking and keep noodles from sticking together. Rinse cooked noodles thoroughly in cold water to remove excess starches.

Tips for Bread Dough Kneading

- The dough kneading function will yield a smooth, elastic dough ball. In some instances, an extra dough kneading cycle is required for optimal results.
- Use a small silicone spatula to assist when adding proofed yeast through the opening in the lid.
- Most dough recipes require more than 1 cup (250 ml) of liquid; use a 2-cup (500 ml) liquid measuring cup for proofing yeast and combining liquid ingredients.
- It is recommended to add the liquid ingredients in a “zigzagging” motion in order to evenly distribute the liquid into the dry ingredients.
- Add the liquid slowly but steadily to the mixing bowl through the lid until the liquid is absorbed by the flour. Reserve a small amount of the liquid. Should the dough seem dry, add all of the liquid.
- If dough is too sticky, add additional flour, a tablespoon (15 ml) at a time while kneading.
- During the winter or drier months, the amount of water may need to be increased. During the warmer or more humid months, the amount of water may need to be reduced.
- Be sure to spoon flour, rather than dip the measuring cup into the flour. Fill the cup over the top and then level off with a straight edge.
- Butter that is not melted should be added with the dry ingredients. Cut into small cubes and bring to room temperature before adding.

PASTA RECIPE CHART

Read all Pasta Tips and Hints before making pasta for the first time, as the correct pasta dough consistency is important for successful pasta making.

DOUGHS	INGREDIENTS			TIPS	RECOMMENDED COOKING TIME	PASTA DISCS
Basic Pasta	All-purpose flour Table salt Large eggs, lightly beaten Water	3 cups (750 ml) ½ teaspoon (2.5 ml) 2 ¼ cup (60 ml)	360 g - 100 g 60 ml	Add eggs first to the dry ingredients when mixing. Gradually add remaining water until mixture resembles a coarse meal. It is better for it to be too dry than too wet.	About 2 minutes for thinnest spaghetti and 4 minutes for thickest rigatoni for al dente pasta.	All discs
Semolina Pasta	Semolina flour 00 flour Table salt Large egg, lightly beaten Water	2 cups (500 ml) ⅔ cup (150 ml) ½ teaspoon (2.5 ml) 1 ½ cup (125 ml)	315–320 g 80 g - 50 g 118 ml	Semolina pasta is a heartier recipe and holds up well to all shapes and cuts.	About 3 minutes for thinnest spaghetti and 6 minutes for thickest rigatoni for al dente pasta.	All discs
Beet, Butternut Squash and Spinach-Coloured Pastas	Semolina flour 00 flour Table salt Purée (See instructions for making purées on page 15.) Large egg, lightly beaten	2 cups (500 ml) ⅔ cup (150 ml) ½ teaspoon (2.5 ml) 1 ½ cup (125 ml)	315–320 g 80 g - 50 g 120 ml	The purée is added to the mixing bowl with the dry ingredients. Once the program is started, add the egg through the opening on the lid to mix and extrude pasta.	About 2 minutes for thinnest spaghetti and 4 minutes for thickest rigatoni for al dente pasta.	All discs
Whole-Wheat Pasta	Whole-wheat flour All-purpose flour Table salt Large egg, lightly beaten Extra virgin olive oil Water	1½ cups (375 ml) 1½ cups (375 ml) ½ teaspoon (2.5 ml) 1 2 tablespoons (30 ml) ¼ cup (60 ml)	165–170 g 180 g - 50 g 25 g 59 ml	Mix egg and oil together. Add first to the dry ingredients when mixing. Gradually add remaining water until mixture resembles a coarse meal.	About 3 minutes for thinnest spaghetti and 6 minutes for thickest rigatoni for al dente pasta.	All discs
Rice Noodles (Gluten-Free)	Rice flour (superfine) Tapioca flour Xanthan gum Table salt Water	2 cups (500 ml) ⅔ cup (150 ml) 1¼ teaspoons (6 ml) ¼ teaspoon (1 ml) ¾ cup (175 ml)	240 g 80 g 5 g - 177 ml	The rice noodles are delicate. Spaghetti and fettuccine are the recommended cuts.	About 2–3 minutes for spaghetti and 4–5 minutes for fettuccine. Transfer cooked noodles to ice-water bath; drain and rinse before use.	Spaghetti, Fettuccine

VEGETABLE PURÉES FOR COLOURED PASTA

Vegetables colour pasta noodles naturally and also add nutrients without affecting flavour.

Beet Purée for Red-Coloured Pasta

Makes ½ cup (125 ml)

**1 medium-large beet (about 5½ ounces [155 g]),
cleaned and trimmed**

1. Preheat the oven to 350°F (180°C). Wrap the beet in foil and roast on a sheet pan for 55 to 60 minutes, until tender enough to be easily pierced with the tip of a sharp knife. Remove from oven and let cool in foil.
2. When the beet is cool enough to handle, gently rub off skin under cool, running water. Roughly chop the beet, then transfer to the work bowl of a food processor and purée until smooth.

Nutritional information for ½ cup (125 ml) of purée:

*Calories 67 (4% from fat) • carb. 16g • pro. 3g • fat 0g • sat. fat 0g
chol. 0mg • sod. 122mg • calc. 16mg • fiber 4g*

Butternut Squash Purée for Orange-Coloured Pasta

Makes 2½ cups (625 ml)

**1 butternut squash (about 2 pounds [907 g]),
halved lengthwise and seeded**

1 tablespoon (15 ml) olive oil

1. Preheat the oven to 375°F (190°C). Place squash halves on a rimmed sheet pan and coat all over with olive oil. Roast cut side down for 35 to 40 minutes, until skin has wrinkled and you can easily pierce through flesh with a sharp knife. Let cool slightly.
2. Scoop flesh out into the work bowl of a food processor and discard skin. Purée until smooth.

Nutritional information per ½ cup (125 ml) of purée:

*Calories 106 (22% from fat) • carb. 22g • pro. 2g • fat 3g • sat. fat 0g
chol. 0mg • sod. 7mg • calc. 87mg • fiber 4g*

Spinach Purée for Green-Coloured Pasta

Makes about ¾ cup (175 ml)

1 5-ounce (145 g) clamshell baby spinach

1. Bring a medium pot of water to a rolling boil. Meanwhile, fill a medium-size bowl with ice and cold water, and set it near the stove. Add the spinach to the boiling water, pushing down with a slotted spoon to fully submerge, and blanch until leaves turn dark green, about 1 minute. Quickly transfer spinach to the prepared ice bath to halt cooking.
2. Drain spinach well and squeeze out any excess water. Transfer to the bowl of a food processor and purée until smooth.

Nutritional information for ½ cup (125 ml) of purée:

*Calories 31 (0% from fat) • carb. 4g • pro. 3g • fat 0g • sat. fat 0g
chol. 0mg • sod. 106mg • calc. 90mg • fiber 3g*

NUTRITIONAL INFORMATION FOR PASTA RECIPES

Pasta recipes extrude approximately 1 pound (454 g) of pasta and make enough for about 6 servings.

**Nutritional information per serving of Basic Pasta
(based on 6 servings):**

Calories 243 (6% from fat) • carb. 44g • pro. 10g • fat 2g • sat. fat 0g
chol. 0mg • sod. 219mg • calc. 10mg • fiber 2g

**Nutritional information per serving of Semolina Pasta
(based on 6 servings):**

Calories 235 (7% from fat) • carb. 45g • pro. 8g • fat 2g • sat. fat 0g
chol. 31mg • sod. 212mg • calc. 9mg • fiber 2g

**Nutritional information per serving of Whole-Wheat Pasta
(based on 6 servings):**

Calories 255 (21% from fat) • carb. 42g • pro. 9g • fat 6g • sat. fat 1g
chol. 31mg • sod. 209mg • calc. 16mg • fiber 4g

**Nutritional information per serving of Rice Noodles
(based on 6 servings):**

Calories 251 (3% from fat) • carb. 55g • pro. 3g • fat 1g • sat. fat 0g
chol. 0mg • sod. 124mg • calc. 9mg • fiber 1g

SAUCES AND DISHES

Tomato Sauce

This classic sauce pairs well with regular or whole-wheat pasta.

Makes about 3 cups (750 ml);
enough sauce for ½ pound (227 g) of pasta

- ½ **cup (125 ml) olive oil**
- 2 medium garlic cloves, smashed with the back of a knife**
- 1 large can (28 ounces [796 ml]) crushed tomatoes**
- ¼ **cup (60 ml) grated Parmesan cheese**
- 1 teaspoon (5 ml) kosher salt**
- 10 leaves fresh basil**

1. In a large saucepan, heat garlic and oil over medium-high heat until lightly golden and fragrant, about 5 minutes. Add the crushed tomatoes, reduce the heat and cook at a low simmer until reduced by about one-third, about 15 minutes.
2. When the sauce is reduced, stir in the Parmesan cheese, salt and basil and cook for 1 additional minute.
3. For best-tasting pasta, add the cooked and drained pasta to the pan with the sauce and cook for 1 minute. Serve immediately.

Nutritional analysis per serving (½ cup [125 ml]):

Calories 224 (75% from fat) • carb. 11g • pro. 4g • fat 20g • sat. fat 4g
chol. 5mg • sod. 483mg • calc. 64mg • fiber 2g

Smoky Vodka Sauce

Bacon adds a depth of smoky flavour to this version of the beloved sauce. Reserving the bacon until the end preserves its integrity and adds a satisfying crunch element to the finished dish.

Makes about 5 cups (1.25 L) of sauce

- 4 ounces [113 g (about 4 slices)] smoked bacon, such as applewood-smoked, cut crosswise into thin strips**
- 1 medium onion, finely chopped**
- 2 garlic cloves, finely chopped**
- ¼ cup (60 ml) double-concentrated tomato paste**
- ⅓ cup (75 ml) vodka**
- 1 large can (28 ounces [793 g]) crushed tomatoes**
- 1 teaspoon (5 ml) salt**
- ½ teaspoon (2.5 ml) freshly ground black pepper**
- 1 cup (250 ml) heavy cream**
- 2 tablespoons (30 ml) basil leaves, chiffonade**
Grated Parmesan, for serving

1. Add the bacon to a cold Dutch oven or large, heavy skillet and heat over low heat. Sauté bacon, stirring occasionally, until rendered and crisp, about 10 minutes. Use a slotted spoon to transfer bacon to a paper towel-lined plate and reserve.
2. Add the onion and garlic to the rendered bacon fat and sauté over medium heat, stirring frequently, until soft and just golden, about 5 to 7 minutes. Add the tomato paste and cook, stirring, until deepened in colour, about 2 minutes.

Deglaze with vodka. Stir in the crushed tomatoes, salt and black pepper. Bring the sauce to a simmer and cook, stirring occasionally, until thickened, about 15 minutes. Lower the heat and stir in the heavy cream. For a smooth sauce, transfer sauce to the jar of a blender, or use an immersion blender, to blend until velvety smooth. Pour sauce back into the cooking vessel and let simmer for 5 minutes.

3. To serve, toss sauce with pasta, reserved bacon, basil and grated Parmesan.

Nutritional information per serving (½ cup [125 ml]):

*Calories 169 (67% from fat) • carb. 10g • pro. 3g • fat 11g • sat. fat 7g
chol. 36mg • sod. 401mg • calc. 48mg • fiber 3g*

Alfredo Sauce

A little of this traditional and creamy sauce goes a long way. Pair it with any type of pasta, in addition to the standard fettucine.

Makes about 2 cups (500 ml)

- 2 cups (500 ml) heavy cream**
- 2 garlic cloves, crushed**
- 4 ounces (113 g) Parmigiano-Reggiano cheese, grated**
- 3 ounces (85 g) Italian Fontina cheese, shredded**
- 4 ounces (113 g) mascarpone**
- ½ teaspoon (2.5 ml) freshly ground white pepper**
- ¼ teaspoon (1 ml) freshly grated nutmeg**

1. Put the heavy cream and garlic into a medium saucepan and place over medium heat. Keep an eye on the cream – once it just comes to a boil, reduce heat immediately, in order to

- maintain a steady simmer. Cream will boil over if temperature is not reduced.
2. Allow to simmer for about 15 minutes. Cream should be reduced and thickened.
 3. Stir in the cheeses with the mascarpone. Stir over low heat until incorporated and thickened. Season with the pepper and nutmeg.
 4. Taste and adjust seasoning according to preference.

Nutritional information per serving (based on ¼ cup [60 ml]):

Calories 368 (85% from fat) • carb. 3g • pro. 10g • fat 35g • sat. fat 22g
chol. 122mg • sod. 338mg • calc. 242mg • fiber 0g

Garden Vegetable Sauce

*Make this sauce in the height of summer
when veggies are in abundance.*

Makes about 6 cups (1.5 L)

- 2 tablespoons (30 ml) olive oil**
- 2 medium onions, cut into small dice**
- 4 carrots, cut into 1-inch (2.5 cm) dice**
- 2 celery stalks, cut into 1-inch (2.5 cm) dice**
- 1½ teaspoons (7.5 ml) sea or kosher salt, divided**
- 1 Japanese eggplant, cut into 1- to 2-inch (2.5 to 5 cm) dice**
- 1 small zucchini, cut into 1- to 2-inch (2.5 to 5 cm) dice**
- 1 small yellow squash, cut into 1- to 2-inch (2.5 to 5 cm) dice**

- 4 garlic cloves, finely chopped**
- 1½ teaspoons (7.5 ml) dried oregano**
- 1½ teaspoons (7.5 ml) dried basil**
- 4 roasted red bell peppers,
cut into 1-inch (2.5 cm) pieces**
- ¼ cup (60 ml) dry white wine**
- 3 tablespoons (45 ml) tomato paste**
- 4 cans diced tomatoes, strained,
reserving 1 cup (250 ml) of the juices**
- ¼ teaspoon (1 ml) freshly ground black pepper**
- 3 tablespoons (45 ml) granulated sugar**

1. Put the olive oil into a 4- to 6-quart (4.54 to 6.82 L) saucepan/stockpot and place over medium heat. Once the oil is hot and shimmers across the pan, add the diced onion, carrots, and celery with ½ teaspoon (2.5 ml) of salt. Stir occasionally until vegetables are soft.
2. Add the eggplant, zucchini, squash and garlic and continue to cook, stirring occasionally over the heat for about 10 minutes. All vegetables should be softened.
3. Once vegetables are soft, add the oregano, basil and prepared roasted red peppers. Stir together to fully incorporate.
4. Add the wine and simmer until wine evaporates.
5. Once wine evaporates, add the tomato paste, canned tomatoes with 1 cup (250 ml) of reserved juices, remaining ½ teaspoon (2.5 ml) salt, pepper and sugar. Bring mixture to a boil and then reduce the temperature to maintain a simmer.
6. Allow to simmer for 2 to 3 hours to allow all flavours to develop.
7. Taste and adjust seasoning according to preference.

Note: If a smoother sauce is preferred, blend with a hand blender or blender.

Nutritional information per serving (¼ cup [60 ml]):

Calories 55 (6% from fat) • carb. 11g • pro. 2g • fat 0g • sat. fat 0g
chol. 0mg • sod. 433mg • calc. 32mg • fiber 2g

Garlic and Oil Sauce

Makes about ¼ cup (60 ml) of sauce;
enough for ½ pound (227 g) of pasta

- ¼ **cup (60 ml) olive oil, plus more if needed**
- 2 garlic cloves, thinly sliced**
Pinch red pepper flakes
- 3 tablespoons (45 ml) fresh parsley, roughly chopped**
Grated cheese for serving, optional

1. In a large saucepan, heat the oil and garlic over medium-high heat until golden and fragrant, about 5 to 6 minutes. Add the red pepper flakes and cook for 1 additional minute.
2. Remove from heat and add 2 ounces (57 g) of cooking water from the pasta. Add the cooked and drained pasta, and return the pan to the heat. Cook over medium heat until the pasta water evaporates, about 1 to 2 minutes. Stir in parsley and remove from heat. Serve immediately with grated cheese if desired.

Nutritional analysis per serving (based on 3 servings):

Calories 165 (97% from fat) • carb. 1g • pro. 0g • fat 19g • sat. fat 3g
chol. 0mg • sod. 2mg • calc. 9mg • fiber 0g

Sautéed Mushroom and Butter Sauce

Sophisticated flavour, simple ingredients and basic technique.

Makes about 1½ cups (375 ml);
enough for ½ pound (227 g) pasta

- 4 tablespoons (60 ml) unsalted butter**
- 1 teaspoon (5 ml) marjoram**
- 8 ounces (227 g) mixed wild mushrooms, like cremini, shiitake and oyster**
- 1 teaspoon (5 ml) kosher salt**
- 2 tablespoons (30 ml) olive oil**
- 2 tablespoons (30 ml) thinly sliced basil**
- ¼ **teaspoon (1 ml) freshly ground black pepper**

1. In a large saucepan, melt the butter over medium-high heat until it starts to foam. Add the marjoram and cook until fragrant, about 30 seconds. Add the mushrooms and cook until browned on one side, about 3 minutes.
2. Add salt and stir; cook mushrooms for an additional 3 to 4 minutes on the other side.
3. Stir in cooked and drained pasta. Drizzle with olive oil and sprinkle with thinly sliced basil and freshly ground pepper. If a thinner sauce is desired, add ¼ cup of pasta water.

Nutritional analysis per serving (based on 3 servings):

Calories 240 (88% from fat) • carb. 5g • pro. 3g • fat 24g • sat. fat 12g
chol. 40mg • sod. 724mg • calc. 5mg • fiber 2g

Basil Pesto

For a spin on the traditional recipe, substitute the pine nuts in this recipe with toasted hazelnuts, and the basil with 2½ ounces (70 g) arugula and 1½ ounces (43 g) baby spinach leaves.

Makes about 1½ cups (375 ml)

- 2 ounces (57 g) Parmesan cheese, cut into ½-inch (1.25 cm) cubes**
- 1 garlic clove, peeled**
- ¼ cup (60 ml) pine nuts, lightly toasted**
- 4 ounces (113 g) fresh basil leaves (about 3 cups [750 ml])**
- ¼ teaspoon (1 ml) kosher salt**
- ½ – ⅔ cup (125 - 150 ml) extra virgin olive oil**

1. Fit the work bowl of a Cuisinart® Food Processor with a chopping blade. With the food processor running on High, drop the Parmesan cubes and garlic through the feed tube to finely chop. Add the pine nuts and pulse to chop, about 5 to 6 times. Add the basil and salt. Pulse to chop, about 10 to 15 times. Scrape the sides of the bowl.
2. With the machine running on High, add the olive oil in a steady stream through the small feed tube. Process until combined, about 1 minute.
3. Use immediately or store in an airtight container in the refrigerator until ready to use.

Nutritional information per serving (2 tablespoons [30 ml]):

*Calories 120 (90% from fat) • carb. 1g • pro. 2g • fat 13g • sat. fat 2g
chol. 3mg • sod. 121mg • calc. 74mg • fiber 0g*

Sunday Ragu

The deep and rich flavours of this hearty sauce make for a memorable Sunday meal. Pair with a tubular pasta like rigatoni, and don't forget to pass the Pecorino Romano!

Makes about 6 cups (1.5 L)

- 1 pound (454 g) beef short ribs**
- ½ pound (227 g) pork shoulder, cut into 2-inch (5 cm) pieces**
- ½ pound (227 g) fresh sweet pork sausage, casings removed**
- 1 teaspoon (5 ml) kosher salt**
- ½ teaspoon (2.5 ml) freshly ground black pepper**
- 2 teaspoons (10 ml) olive oil**
- 3 garlic cloves, finely chopped**
- 1 small carrot, finely chopped**
- 1 small celery stalk, finely chopped**
- 1 small leek, cleaned well and finely chopped**
- 1 shallot, finely chopped**
- 2 fresh thyme sprigs**
- ½ cup (125 ml) dry red wine**
- 1 can (28 ounces [793 g]) plum tomatoes, pulsed with a food processor, hand blender or completely broken up with a flat-edge wooden spoon or spatula**
- 2 tablespoons (30 ml) tomato paste**
- 1 bay leaf**

1. Season the short ribs and pork on all sides with the salt and pepper.
2. Place a 5-quart (5.68 L) casserole dish with tight-fitting lid (cast iron is preferred) over medium heat and add the olive oil.
3. Once the oil is hot and glides across the pan, add the short ribs and some of the cubed pork, being careful not to overcrowd the pan. Brown the meat well on all sides. Remove and reserve. Repeat with the remaining pork and, finally, the uncased sausage. Brown all well, remove and reserve.
4. Add the chopped aromatic vegetables with the thyme sprigs to the pan, scraping up any browned bits that have accumulated on the bottom of the pan.
5. Once the vegetables have softened, add the red wine. Allow the wine to come to a boil and then simmer to fully reduce.
6. Add the chopped tomatoes, tomato paste and bay leaf to the pot, stir together and bring mixture to a boil. Once boiling, reduce heat to maintain a simmer. Add the reserved meat with any accumulated juices and cover, reducing the heat to low to maintain a simmer.
7. Preheat oven to 300°F (150°C).
8. Cover and slow cook in oven for 3 to 4 hours, until meat is completely fork tender.
9. Once cool enough to handle, shred meat finely, discarding any bones.
10. Taste and adjust seasoning according to preference.
11. If time allows, make this sauce in advance. Flavours will fully develop if left overnight to cool in the refrigerator.

Nutritional information per serving (based on ½ cup [125 ml]):

Calories 184 (45% from fat) • carb. 5g • pro. 14g • fat 11g • sat. fat 4g
chol. 51mg • sod. 400mg • calc. 20mg • fiber 1g

Classic Meatballs

*For melt-in-your-mouth meatballs, look no further.
Spaghetti's match made in heaven!*

Makes about 24 meatballs, 4 to 6 servings

- 1 cup (250 ml) fresh breadcrumbs (from about 2 ounces [57 g] day-old white bread, crusts removed)**
- ⅓ cup (75 ml) buttermilk**
- ¾ pound (340 g) ground beef, preferably 20 percent fat**
- ¾ pound (340 g) ground pork**
- 3 large garlic cloves, minced**
- 1 small onion, finely chopped**
- 2 large eggs, lightly beaten**
- ½ cup (125 ml) finely grated Parmigiano-Reggiano cheese, plus more for serving**
- 1½ teaspoons (7.5 ml) kosher salt**
- ¾ teaspoon (3.75 ml) freshly ground black pepper**
- ¼ cup (60 ml) finely chopped Italian parsley**
- 1 tablespoon (15 ml) finely chopped fresh basil**
- 2 teaspoons (10 ml) finely chopped fresh oregano**
- Extra virgin olive oil for coating the sheet pan**
- Warm tomato sauce, for serving**

1. In a small bowl, pour the buttermilk over the breadcrumbs and mix to evenly moisten. Set aside to soak for 10 minutes. Meanwhile, prepare the rest of the meatball mixture.
2. Break up the ground meat into a large mixing bowl. Add the remaining ingredients along with the reserved panade (the soaked breadcrumb mixture) and use your hands to gently fold the meat over itself, incorporating everything together, being careful not to overmix. Cover with plastic wrap and refrigerate for 1 hour.
3. Lightly coat a rimmed sheet pan with olive oil. Portion mixture using a medium cookie scoop to get 24 meatballs (approximately 2 tablespoons [30 ml] of mixture; 1½ ounces [43 g] if you have a food scale). Use moistened hands to shape into balls and arrange 1 inch apart on the prepared sheet pan. Cover with plastic wrap and refrigerate for 30 minutes (skip this step if pressed for time, but it helps meatballs to hold their shape in the oven).
4. Fifteen minutes before baking the meatballs, position oven racks to the middle and top of the oven and preheat the oven to 425°F (220°C). Bake meatballs on the middle rack for 10 minutes, then set on the top rack and broil for 2 minutes, until golden brown.
5. Add meatballs to warm tomato sauce. Serve as a side or atop spaghetti sprinkled with grated Parmesan. Turn leftovers into a pizza topping.

Nutritional information per meatball (without tomato sauce):

*Calories 86 (59% from fat) • carb. 2g • pro. 7g • fat 6g • sat. fat 2g
chol. 39mg • sod. 185mg • calc. 32mg • fiber 0g*

Pad Thai

Nothing makes this dish better than fresh, homemade rice noodles. Do not pass on any of the lesser-known ingredients here, as they capture all the sweet, sour, umami flavours of authentic Pad Thai.

Serves 6

- ⅓ **cup (75 ml) dark brown sugar, packed**
- ⅓ **cup (75 ml) water**
- ⅓ **cup (75 ml) tamarind concentrate**
- ¼ **cup (60 ml) fish sauce**
- ¼ **cup (60 ml) grapeseed oil, divided**
- ½ **pound (227 g) large shrimp, peeled, deveined and butterflied**
- 4 large eggs, beaten**
- 9 ounces (255 g) extra-firm tofu, pressed for at least 30 minutes, cubed**
- 1 shallot, finely chopped**
- 2 garlic cloves, finely chopped**
- ¼ **cup (60 ml) dried shrimp, finely ground**
- Big pinch of crushed red pepper flakes**
- ¼ **cup (60 ml) Thai sweet preserved daikon radish, diced**
- 1 prepared recipe of fettucine rice noodles (cooked, rinsed and drained well)**
- 20 garlic chives, cleaned, trimmed and cut into 2-inch (5 cm) lengths**
- 3 heaping cups (750 ml) mung bean sprouts**

-
- 1/3 cup (75 ml) dry-roasted peanuts,
a combination of rough and finely chopped
Toasted Thai chile powder, for sprinkling
Lime wedges, for serving**
1. In a small saucepan, bring the brown sugar and water to a boil over medium-low heat, stirring constantly, until the sugar has dissolved. Remove from the heat and stir in the tamarind concentrate and fish sauce. Reserve sauce. Gather all the remaining ingredients and set them near your cooking station. The Pad Thai cooks up quickly – so you will want everything at arm’s length!
 2. Heat a large wok over medium-high heat until hot. Add about 2 tablespoons of oil and swirl to coat the pan. When oil is shimmering, scatter the shrimp in a single layer and cook, undisturbed, until firm and pink, about 45 seconds. Toss shrimp and continue to cook until fully opaque and cooked through. Use a slotted spoon to quickly transfer shrimp to clean bowl and reserve.
 3. Add the eggs and swirl the pan to spread them into a thin layer, as if making an omelet. Use a heatproof spatula to gently lift the edges of omelet, tilting the wok, to let any uncooked egg flow underneath. If the wok starts to smoke at any point, lower the heat. When eggs are set, use the spatula to carefully roll the omelet, then tip the wok to release onto a clean plate. Break up egg and reserve.
 4. Add a tablespoon (15 ml) of oil to the wok and swirl to coat. When oil is hot, add the tofu and cook undisturbed, until the undersides are golden brown and crisp, about 1 minute. Continue to cook until golden brown on all sides. Transfer to the bowl with the shrimp.

5. Add the last tablespoon (15 ml) of oil to the wok and swirl to coat. Add the shallot and garlic and stir-fry until fragrant and golden, about 1 minute. Stir in the dried shrimp, crushed red pepper flakes, and the sweet daikon radish and cook for 30 seconds longer. Add the rice noodles and pour in about two-thirds of the sauce around the edge of the wok. Stir-fry until most of the sauce has been absorbed. Add the garlic chives and then bean sprouts and toss with the noodles. Pour in the remaining sauce and continue to stir-fry for 45 to 60 seconds longer. Add the reserved proteins to the wok and toss with the noodles. Remove the wok from the heat.
6. Sprinkle the peanuts over the top and sprinkle with chile powder. Serve immediately with lime wedges to squeeze over top.

Nutritional information per serving (based on 6 servings):

*Calories 630 (26% from fat) • carb. 92g • pro. 25g • fat 19g • sat. fat 3g
chol. 198mg • sod. 1,583mg • calc. 576mg • fiber 5g*

BREAD

Classic Cuisinart® White Bread

Spoil your family with homemade bread.

Makes 12 servings (one 9 x 5-inch [23 x 13 cm] loaf)

- 2¼ teaspoons (11 ml) active dry yeast**
- 1½ teaspoons (7.5 ml) granulated sugar**
- 1 cup (250 ml) warm water (105°F to 110°F [40°C to 43°C])**
- 3 cups (750 ml) unbleached, all-purpose flour**

**2 tablespoons (30 ml) unsalted butter,
cut into small cubes, room temperature**

1 teaspoon (5 ml) salt
Nonstick cooking spray

1. Dissolve the yeast and sugar in warm water in the liquid measuring cup. Let sit until foamy, about 5 minutes.
2. Assemble the Cuisinart® Pastafecto® Pasta/Bread Dough Maker with the dough kneading paddle. Place the flour, butter, and salt in the mixing bowl. Secure the lid.
3. Select Knead Bread to start kneading.
4. Slowly pour the yeast mixture through the opening in the lid, in a zigzagging stream, to evenly distribute. The dough will have a shaggy appearance at first, until all the liquid is absorbed and it comes together into a sticky ball. The dough should be smooth and elastic. If necessary, add another knead cycle for a smooth dough ball.
5. When the kneading ends, remove lid and take out the dough ball, using a spatula to unstick the dough from the paddle, if needed. Place the dough into a large mixing bowl and cover with plastic wrap. Allow to rest in a warm, draft-free place until doubled in size, about 1 to 1½ hours.
6. Lightly coat one 9 x 5-inch (23 x 13 cm) loaf pan with nonstick cooking spray. Place dough on a lightly floured surface and punch down; let rest 5 to 10 minutes.
7. Shape dough into a loaf and place in prepared pan and cover lightly with plastic wrap. Let rise until dough is just above the top of the pan, about 45 minutes to 1 hour.
8. Preheat oven to 400°F (200°C).

9. Bake until the top is browned and loaf sounds hollow when tapped, about 30 to 35 minutes. Remove from pan and cool on wire rack.

Nutritional information per slice:

*Calories 139 (19% from fat) • carb. 25g • pro. 3g • fat 3g • sat. fat 2g
chol. 8mg • sod. 243mg • calc. 30mg • fiber 1g*

Classic Cuisinart® Wheat Bread

The nutty flavour of whole wheat makes this bread a favourite.

Makes 12 servings (one 9 x 5-inch [23 x 13 cm] loaf)

2¼ teaspoons (11 ml) active dry yeast
2 teaspoons (10 ml) granulated sugar
**1 cup (250 ml) warm water (105°F to 110°F
[40°C to 43°C])**
1½ cups (375 ml) unbleached, all-purpose flour
1½ cups (375 ml) whole-wheat flour
**3 tablespoons (45 ml) unsalted butter,
cut into small cubes, room temperature**
1½ teaspoon (7.5 ml) salt
Nonstick cooking spray

1. Dissolve the yeast and sugar in warm water in the liquid measuring cup. Let sit until foamy, about 5 minutes.
2. Assemble the Cuisinart® Pastafecto® Pasta/Bread Dough Maker with the dough kneading paddle. Place the flours, butter, and salt in the mixing bowl. Secure the lid.
3. Select Knead Bread to start kneading.

4. Slowly pour the yeast mixture through the opening in the lid, in a zigzagging stream, to evenly distribute. The dough will have a shaggy appearance at first, until all the liquid is absorbed and it comes together into a sticky ball. The dough should be smooth and elastic. If necessary, add another knead cycle for a smooth dough ball.
5. When the kneading ends, remove lid and take out the dough ball, using a spatula to unstick the dough from the paddle, if needed. Place the dough into a large mixing bowl and cover with plastic wrap. Allow to rest in a warm, draft-free place until doubled in size, about 1 to 1½ hours.
6. Lightly coat a 9 x 5-inch (23 x 13 cm) loaf pan with nonstick cooking spray. Place dough on a lightly floured surface and punch down; let rest 5 to 10 minutes. Shape the dough into a loaf. Place in prepared pan and cover lightly with plastic wrap. Let rise until dough is just above the top of the pan, about 45 minutes to 1 hour.
7. Preheat oven to 400°F (200°C).
8. Bake until the top is browned and loaf sounds hollow when tapped, about 30 to 35 minutes. Remove from pan and cool on wire rack.

Nutritional information per serving (1 slice):

*Calories 135 (20% from fat) • carb. 23g • pro. 4g • fat 3g • sat. fat 2g
chol. 8mg • sod. 244mg • calc. 30mg • fiber 3g*

Challah

*Our challah makes the best French toast —
that's if you have any left over, of course!*

Makes 1 loaf

- | | |
|--|--|
| <p>2¼
3
¼
¾
1½
⅓
1
½</p> | <p>teaspoons active dry yeast
tablespoons granulated sugar, divided
cup warm water (105°F to 110°F [40°C to 43°C])
cups (810 ml) unbleached, all-purpose flour
teaspoons (kosher salt
cup (75 ml) unsalted butter, cut into small cubes,
room temperature
large egg, lightly beaten
cup (125 ml) cold water
Nonstick cooking spray
Egg wash (1 large egg whisked together with
1 tablespoon [15 ml] water)</p> |
|--|--|
1. Dissolve the yeast and 2 teaspoons (10 ml) sugar in warm water in the liquid measuring cup. Let sit until foamy, about 5 minutes.
 2. Assemble the Cuisinart® Pastafecto® Pasta/Bread Dough Maker with the dough kneading paddle. Place the flour, salt, and cubed butter into the mixing bowl.
 3. Add the beaten egg and remaining ½ cup (125 ml) water to the yeast mixture.
 4. Select Knead Bread to start kneading.
 5. Slowly pour the yeast mixture through the opening in the lid, in a zigzagging stream, to evenly distribute. The dough will have a shaggy appearance at first, until all the liquid is absorbed and it comes together into a sticky ball. The dough should be smooth and elastic. If necessary, add another knead cycle for a smooth dough ball.

6. When the kneading ends, remove lid and take out the dough ball, using a spatula to unstick the dough from the paddle, if needed. Place the dough into a large mixing bowl and cover with plastic wrap. Allow to rest in a warm, draft-free place until doubled in size, about 1 to 1½ hours.
7. Line a sheet tray with parchment paper.
8. Transfer dough to a lightly floured surface and punch down. Divide dough into 3 equal pieces. Use your hands to roll each piece into a cylinder, about 1½ x 14 inches (3.75 x 35 cm) . Place the cylinders side by side on the prepared tray. Braid loosely from one end. Gently pull and taper each end to a point, then pinch and tuck under loaf. Place on baking sheet lined with parchment and cover loosely with plastic wrap coated with nonstick cooking spray. Let rise until doubled in size, about 45 minutes.
9. Preheat oven to 375°F (190°C) with the rack positioned in the lower third of the oven.
10. Brush the loaf with the egg wash. Bake for 20 minutes. Lower temperature to 350°F (180°C) and bake until loaf is browned and sounds hollow when tapped, about an additional 10 minutes. Remove from oven and cool on wire rack.

Nutritional information per serving (2-ounce [57 g] slice):

*Calories 119 (61% from fat) • carb. 18g • pro. 3g • fat 4g • sat. fat 2g
chol. 30mg • sod. 202mg • calc. 4mg • fiber 0g*

Buttery Dinner Rolls

Fresh from the oven, warm rolls make any dinner extra special.

Makes 12 rolls

- 6** **tablespoons (90 ml) whole milk**
 - 6** **tablespoons (90 ml) unsalted butter,
plus more for brushing**
 - 3** **tablespoons (45 ml) granulated sugar**
 - 1¾** **teaspoons (9 ml) active dry yeast**
 - 3** **tablespoons (45 ml) warm water (105°F to 110°F
[40°C to 43°C])**
 - 3** **cups (750 ml) bread flour**
 - ¾** **teaspoon (3.75 ml) kosher salt**
 - Egg wash (1 large egg whisked together with
1 tablespoon [15 ml] water)**
1. In a small saucepan, combine the milk, butter and sugar together. Warm over low heat until the butter is melted. Remove from heat and reserve.
 2. Dissolve the yeast and warm water in the liquid measuring cup. Let sit until foamy, about 5 minutes. When the milk mixture has slightly cooled, add it to the bloomed yeast.
 3. Assemble the Cuisinart® Pastafecto® Pasta/Bread Dough Maker with the dough kneading paddle. Place the flour and salt in the mixing bowl. Secure the lid.
 4. Select Knead Bread to start kneading.
 5. Slowly pour almost all the yeast mixture through the opening in the lid, in a zigzagging stream, to evenly distribute. The dough will have a shaggy appearance at first, until all

the liquid is absorbed and it comes together into a sticky ball. Pour the last bit through the opening in the lid nearest to the front of the mixing bowl to incorporate any settled flour. The dough should be smooth and elastic after a few minutes of kneading. If necessary, add another knead cycle for a smooth dough ball.

6. When the kneading ends, remove lid and take out the dough ball, using a spatula to unstick the dough from the paddle, if needed. Place the dough into a large mixing bowl and cover with plastic wrap. Allow to rest in a warm, draft-free place until doubled in size, about 45 to 60 minutes.
7. Preheat oven to 400°F (200°C) . Lightly butter a 9-inch (23 cm) round baking pan. Divide the dough into 12 equal pieces, about 2 ounces (57 g) each. Roll into smooth rounds and arrange in the prepared pan. Cover with plastic wrap and let rise until about doubled, about 30 to 40 minutes.
8. Just before baking, gently brush the rolls with egg wash. Place in preheated oven and bake until golden brown, about 25 to 30 minutes. Remove from pan and let cool on a rack for about 10 minutes before serving.
9. For a softer roll, brush each with melted butter just after removing from oven.

Nutritional information per serving (1 roll):

*Calories 209 (38% from fat) • carb. 28g • pro. 5g • fat 9g • sat. fat 5g
chol. 34mg • sod. 160mg • calc. 23mg • fiber 1g*

Rosemary Olive Oil Rolls

*These rolls go well with dinner,
but could also be used as small sandwich rolls.*

Makes 12 rolls

- ¼ cup (60 ml) flavourful extra virgin olive oil**
- 1½ tablespoons (25 ml) chopped, fresh rosemary**
- 2¼ teaspoons (11 ml) active dry yeast**
- ¾ cup (175 ml) warm water (105°F to 110°F [40°C to 43°C])**
- 3¼ cups (810 ml) unbleached bread or all-purpose flour**
- 1¾ teaspoons (9 ml) sea salt (may use kosher salt)**
- ¼ cup (60 ml) cold water**
- Cornmeal for the baking sheet**

1. Combine the olive oil and rosemary, let stand 10 minutes or longer. Dissolve the yeast in warm water in the liquid measuring cup. Let sit until foamy, about 5 minutes. Add the rosemary olive oil to the bloomed yeast.
2. Assemble the Cuisinart® Pastafacto® Pasta/Bread Dough Maker with the dough kneading paddle. Place the flour and salt in the mixing bowl. Secure the lid.
3. Select Knead Bread to start kneading.
4. Slowly pour the yeast mixture through the opening in the lid, in a zigzagging stream, to evenly distribute. The dough will have a shaggy appearance at first, until all the liquid is absorbed and it comes together into a sticky ball. Pour a little of the ¼ cup (60 ml) cold water through the opening in the lid nearest to the front of the mixing bowl to incorporate

any settled flour, only adding the full amount if the dough looks dry after a couple of minutes of kneading. The dough should be smooth and elastic.

- When the kneading ends, remove lid and take out the dough ball, using a spatula to unstick the dough from the paddle, if needed. Place the dough into a large mixing bowl, lightly dust with flour and cover with plastic wrap. Allow to rest in a warm, draft-free place until doubled in size, about 1 hour. Punch down and let rise again for 1 hour (this second rise can be skipped if pressed for time – but it adds to the flavour and texture). If necessary, add another knead cycle for a smooth dough ball.
- After the second rise, punch dough to deflate and let rest 10 minutes. Lightly dust a baking sheet with cornmeal. Divide dough into 12 equal-size pieces. Roll each piece of dough on a work surface and shape into a ball. Flatten slightly. Transfer to prepared baking pan and cover with plastic wrap. Let rise at room temperature, until almost doubled, about 45 to 60 minutes.
- Fifteen minutes before baking, preheat the oven to 450°F (230°C). Uncover and bake at 450°F(230°C) for 10 minutes. Reduce the heat to 375°F (190°C) and bake for an additional 10 to 15 minutes, until browned and hollow sounding when tapped. Place on a wire rack to cool.

Nutritional information per roll:

*Calories 151 (28% from fat) • carb. 24g • pro. 4g • fat 5g • sat. fat 1g
chol. 0mg • sod. 312mg • calc. 2mg • fiber 1g*

Pizza Dough

*Once you see how simple pizzas are to make,
you will never order one to be delivered again!*

Makes 2 pounds (907 g) dough
(two, 12 to 14-inch [30 to 35 cm] crusts)

- 2¼ teaspoons (11 ml) active dry yeast**
- 1 teaspoon (5 ml) granulated sugar**
- 1 cup (250 ml) warm water (105°F to 110°F [40°C to 43°C])**
- 3½ cups (875 ml) unbleached, all-purpose flour**
- 1½ teaspoons (7.5 ml) kosher salt**
- 1 tablespoon (15 ml) extra virgin olive oil**
- ¼ cup (60 ml) cold water**

Flour for dusting

- Dissolve the yeast and sugar in warm water in the liquid measuring cup. Let sit until foamy, about 3 to 5 minutes.
- Assemble the Cuisinart® Pastafacto® Pasta/Bread Dough Maker with the dough kneading paddle. Place the flour and salt in the mixing bowl. Secure the lid onto the mixing container.
- Select Knead Bread to start kneading.
- Add the olive oil and the remaining ¼ cup (60 ml) cold water to the dissolved yeast, then slowly pour the mixture through the opening in the lid, in a zigzagging stream, to evenly distribute. The dough will have a shaggy appearance at first, until all the liquid is absorbed and it comes together into a

sticky ball. If necessary, add another knead cycle for a smooth, dough ball. The dough should be slightly sticky.

5. When the kneading ends, remove lid and take out the dough ball, using a spatula to unstick the dough from the paddle, if needed. Gather the dough ball on a lightly floured surface, kneading once or twice by hand until a smooth ball is formed. Transfer the dough ball to a large mixing bowl, dust lightly with flour and cover with plastic wrap. Let dough rise in a warm, draft-free place for about 45 minutes, until doubled in size.
6. Place dough on a lightly floured surface; punch down and let rest 5 to 10 minutes. Roll into desired crust sizes and follow favorite pizza recipe, or visit Cuisinart.com for some of our original pizza recipes.

Nutritional information per serving (1 ounce [28 g]):

*Calories 112 (2% from fat) • carb. 24g • pro. 3g • fat 0g • sat. fat 0g
chol. 0mg • sod. 134mg • calc. 0mg • fiber 1g*

WARRANTY

LIMITED THREE-YEAR WARRANTY

We warrant that this Cuisinart product will be free of defects in materials or workmanship under normal home use for 3 years from the date of original purchase. This warranty covers manufacturer's defects including mechanical and electrical defects. It does not cover damage from consumer abuse, unauthorized repairs or modifications, theft, misuse, or damage due to transportation or environmental conditions. Products with removed or altered identification numbers will not be covered.

This warranty is not available to retailers or other commercial purchasers or owners. If your Cuisinart product should prove to be defective within the warranty period, we will repair it or replace it if necessary. For warranty purposes, please register your product online at www.cuisinart.ca to facilitate verification of the date of original purchase and keep your original receipt for the duration of the limited warranty.

This warranty excludes damage caused by accident, misuse or abuse, including damage caused by overheating, and it does not apply to scratches, stains, discolouration or other damage to external or internal surfaces that does not impair the functional utility of the product. This warranty also expressly excludes all incidental or consequential damages.

Your Cuisinart product has been manufactured to the strictest specifications and has been designed for use only in 120 volt outlets and only with authorized accessories and replacement parts. This warranty expressly excludes any defects or damages caused by attempted use of this unit with a converter, as well as use with accessories, replacement parts or repair service other than those authorized by Cuisinart.

If the appliance should become defective within the warranty period, do not return the appliance to the store. Please contact our Customer Service Centre:

Toll-free phone number:
1-800-472-7606

Address:
Cuisinart Canada
100 Conair Parkway
Woodbridge, ON L4H 0L2

Email:
consumer_Canada@conair.com

Model:
PM-1C Series

To facilitate the speed and accuracy of your return, please enclose:

- \$10.00 for shipping and handling of the product (cheque or money order)
- Return address and phone number
- Description of the product defect
- Product date code*/copy of original proof of purchase
- Any other information pertinent to the product's return

* The date code format we are using on unit is WWYY, representing week, and year. eg.2420 = manufactured in 24th week of the year 2020.

Note: We recommend you use a traceable, insured delivery service for added protection. Cuisinart will not be held responsible for in-transit damage or for packages that are not delivered to us.

To order replacement parts or accessories, call our Customer Service Centre at **1-800- 472-7606**. For more information, please visit our website at www.cuisinart.ca.

Cuisinart[®] MD



Food
Processors
Robots
culinaires



Juicers
Centrifugeuses



Coffeemakers
Cafetières



Cookware
Batteries
de cuisine



Tools and
Gadgets
Outils et
gadgets

Cuisinart offers an extensive assortment of top quality products to make life in the kitchen easier than ever.

Try some of our other countertop appliances and cookware, and Savour the Good Life[®].

Découvrez la gamme complète d'appareils de cuisine Cuisinart de qualité supérieure, comprenant robots culinaires, minirobots, batteurs, mélangeurs, grille-pain, cafetières, batterie de cuisine, sorbetières et fours grilloirs à

www.cuisinart.ca

©2021 Cuisinart Canada
100 Conair Parkway,
Woodbridge, ON L4H 0L2

Consumer Call Centre E-mail: | Courriel centre au consommateur :
Consumer_Canada@Conair.com

Printed in China | Imprimé en Chine

20CC076641

IB-16764-CAN